

# NATURE LOO

# CLASSIC 850

INSTALLATION & OPERATION MANUAL



# TABLE OF CONTENTS

<b>ITEMS REQUIRED (NOT INCLUDED)</b>	<b>1</b>
<b>TOOLS REQUIRED</b>	<b>1</b>
<b>CM HIGH PROFILE SCHEMATICS</b>	<b>2</b>
<b>INSTALLATION</b>	<b>3</b>
STEP 1: POSITION THE PEDESTAL	3
STEP 2: POSITION THE WASTE CHUTE	4
STEP 3: INSTALL THE WASTE CHUTE	5
OPTIONAL EXTRA WASTE CHUTE LENGTHS	6
STEP 4: INSTALL THE WHEELS	6
STEP 5: INSTALL THE IN-SERVICE CHAMBER	7
STEP 6: CONNECT THE VENT PIPE AND FAN	8
STEP 7: CONNECT THE FLEXIBLE VENT PIPE AND LIQUID DRAIN HOSE	9
<b>POWERING YOUR FAN</b>	<b>10</b>
<b>LEACHATE DRAIN</b>	<b>11</b>
<b>COMPOST ACCELERATORS</b>	<b>12</b>
<b>STARTING WITH AN EMPTY CHAMBER</b>	<b>13</b>
<b>OPERATION</b>	<b>14</b>
<b>MAINTENANCE</b>	<b>15</b>
<b>ROTATING THE CHAMBERS</b>	<b>16</b>
<b>TROUBLESHOOTING</b>	<b>18</b>
<b>PRODUCT &amp; COMPONENT WARRANTY</b>	<b>20</b>
<b>MAINTENANCE SCHEDULE</b>	<b>21</b>
<b>CONTACT</b>	<b>22</b>

# ITEMS REQUIRED (NOT INCLUDED)

Please check the **packing slip** to ensure everything has been delivered. If anything is missing, please notify Ecoflo within 72 hrs of receipt.

You will need the following items to complete your installation.

## Vent items

- Wall brackets to fix the vent pipe to the building
- A length of 100mm DWV vent pipe to connect to the air exhaust (length depends on specific installation)
- Dektite if DWV vent pipe will penetrate the roof

## Leachate drain items (please check with your local authority)

- Ø100mm Agricultural pipe
- 1.5m x 0.5m Synthetic or Hessian geotextile mat
- 50mm PVC pipe to connect the hose to the agricultural pipe
- 0.30m<sup>3</sup> 20mm Aggregate

A vent kit and drain kit are available to purchase separately from Ecoflo.

# TOOLS REQUIRED

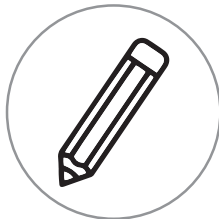

Marker



Tape Measure



Shovel

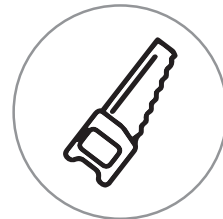

Hand Saw



Caulk Gun

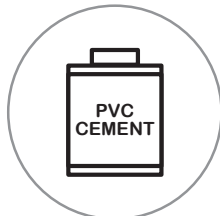

PVC Cement



Plumb Bob

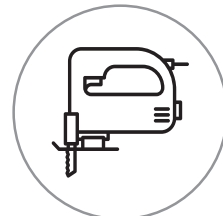

Jigsaw



Power Drill

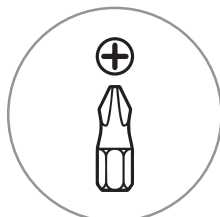

Philips Drill Bit

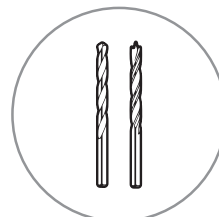

Masonry and Brad Point Drill Bits

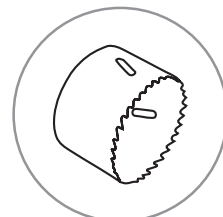

Hole Saw Drill Bit

# CM HIGH PROFILE SCHEMATICS

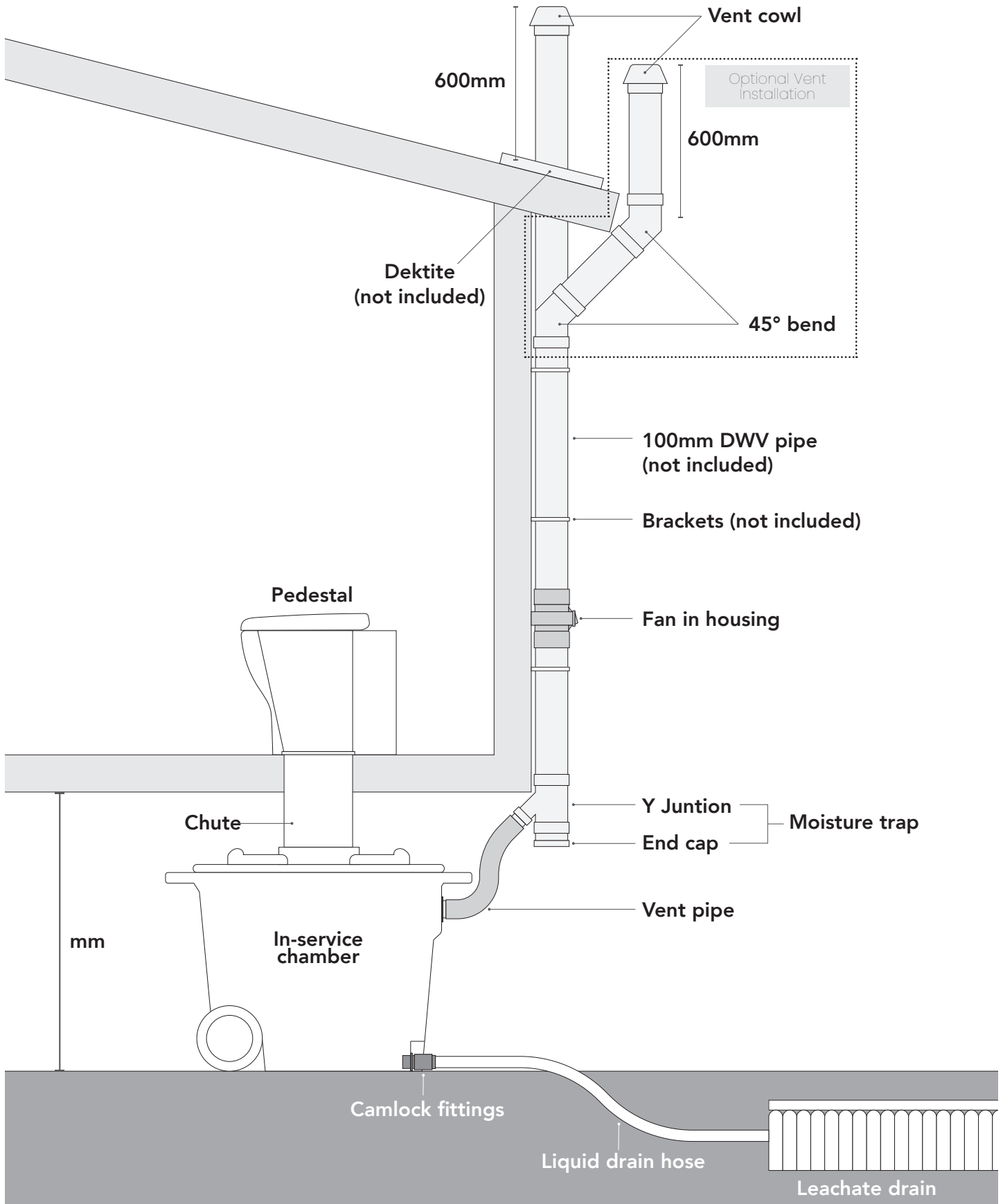

If you are planning to excavate an area under the house for the compost chambers, please ensure the area is well-drained and any retaining walls are built to the satisfaction of the local authority.

# INSTALLATION

## STEP 1: POSITION THE PEDESTAL

---

Locate the approximate area where you want the pedestal to go before cutting the hole.

The usual position for pedestals is centred between side walls.

NOTE: Due to the pedestals being man made, the distance to the centre may vary from 245 to 255mm. Please check before cutting the hole.

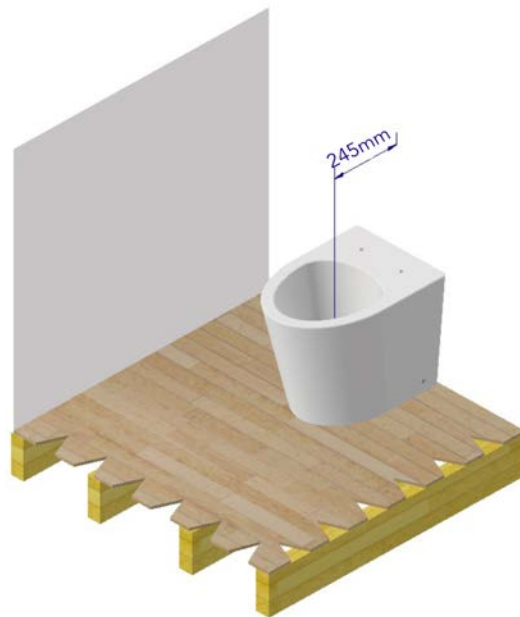

## STEP 2: POSITION THE WASTE CHUTE

A 240mm hole must be cut in the toilet room floor to accommodate the waste chute.

- 1 Following the provided pedestal floor template, mark the location of the centre hole 245-255mm (9.64" -10") from the back wall. Drill a small hole.



Go to the underfloor area and look for the hole you have drilled. Check to see if there is a floor joist, water pipe or electrical wiring under the area you are going to cut.

If there is a joist in the way, either reposition the waste hole OR install trimmer joists to each end of the cut joist, and fix all connections with galvanized framing anchors with 4 nails each leg (refer to diagram below).

### View from under floor

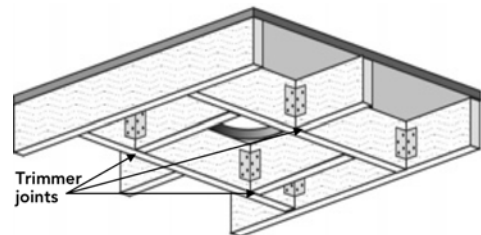

- 2 Following the pedestal floor template, draw a 240mm diameter circle. Cut out the hole with a jigsaw.

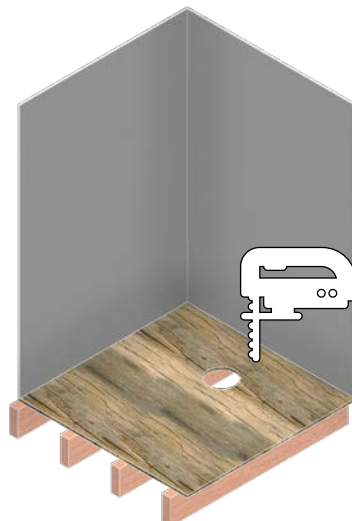

## STEP 3: INSTALL THE WASTE CHUTE

First ensure the pad or ground level on which the 'In-service' chamber will reside is at its final level beneath the toilet room.

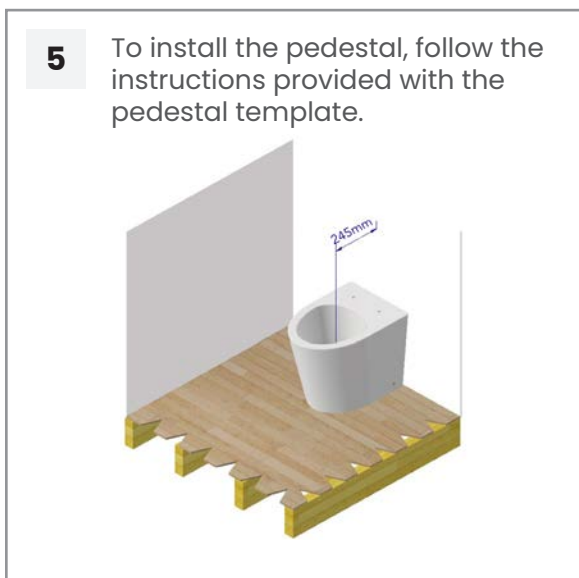
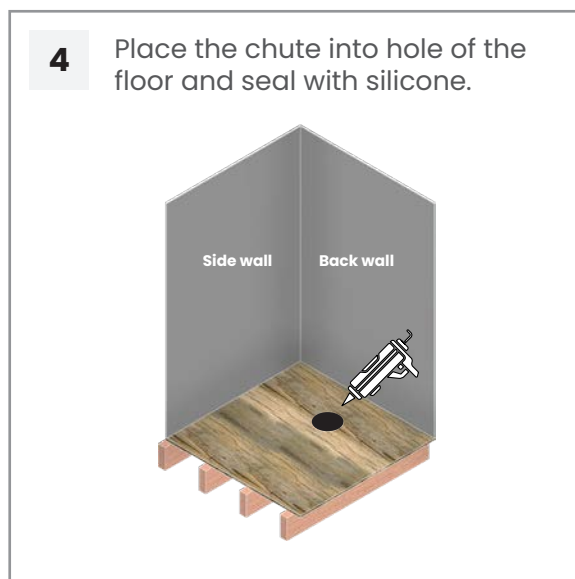
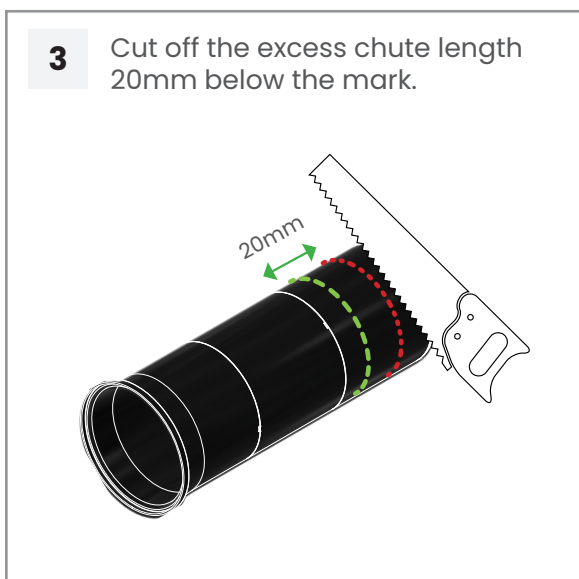
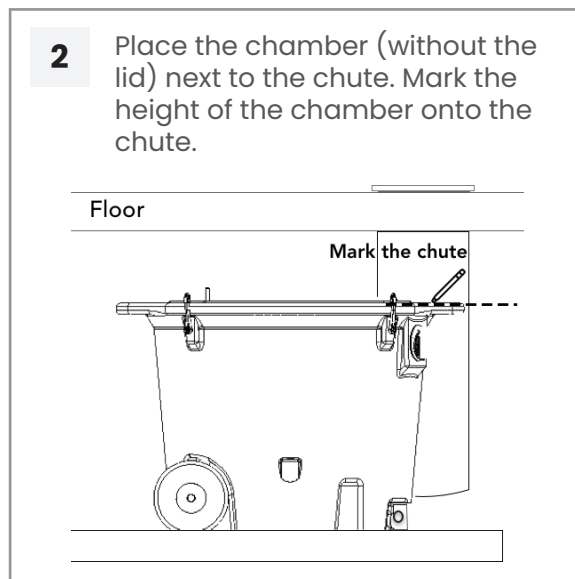
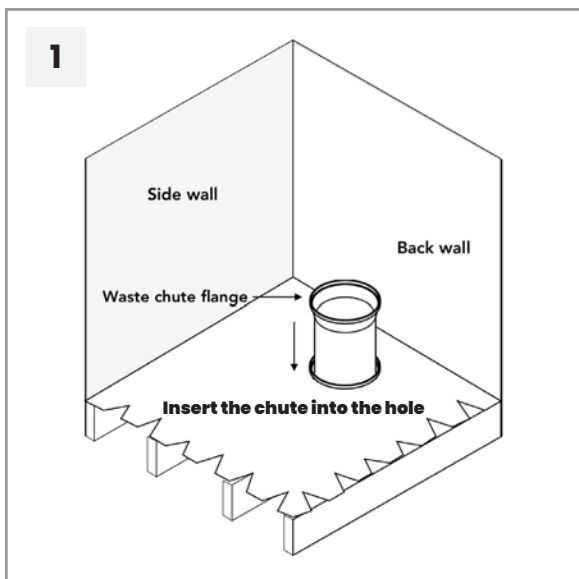

## OPTIONAL EXTRA WASTE CHUTE LENGTHS

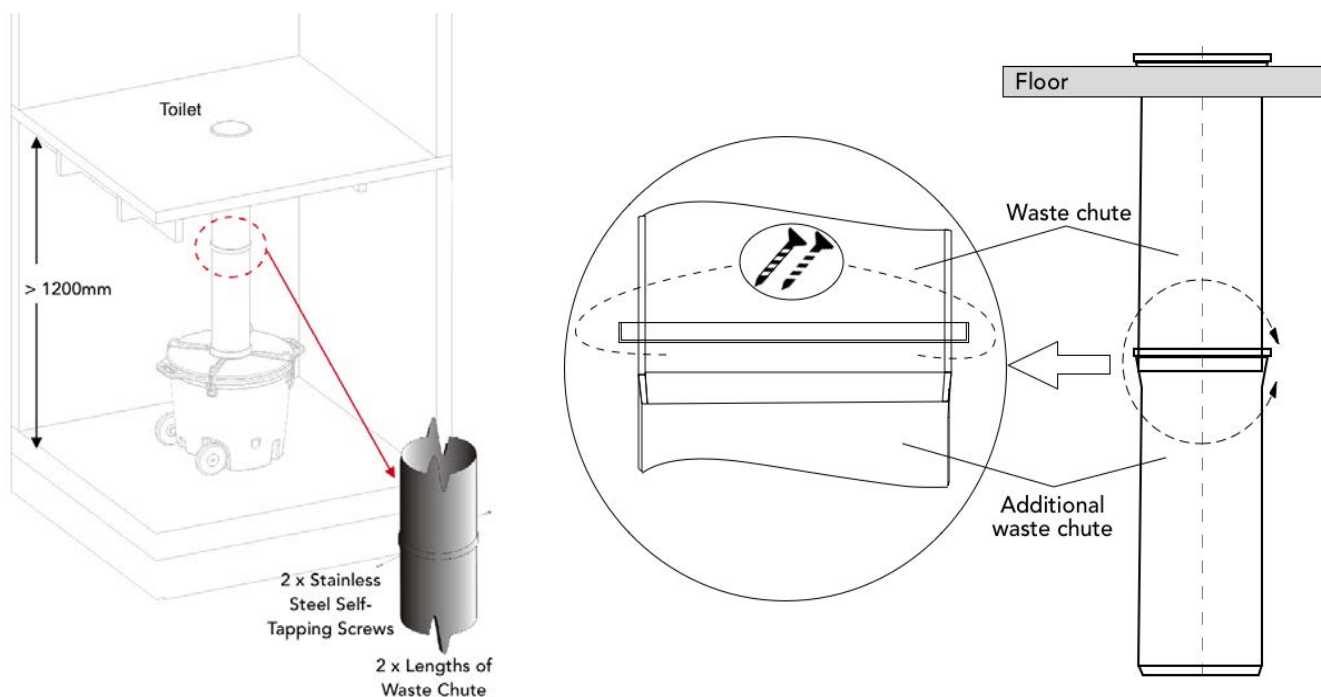

If the underfloor height exceeds 1200mm (floor-to-floor), you will require additional lengths of chute, fixed together with small stainless steel self-tapping screws below the flange of the additional waste chute.

As the chute joints are tapered, the top waste chute must be inserted through the toilet room floor first with additional waste chutes added from below.

## STEP 4: INSTALL THE WHEELS

Push the wheels onto the ends of the axle until you hear them click.

Place the axle in position under the chamber.

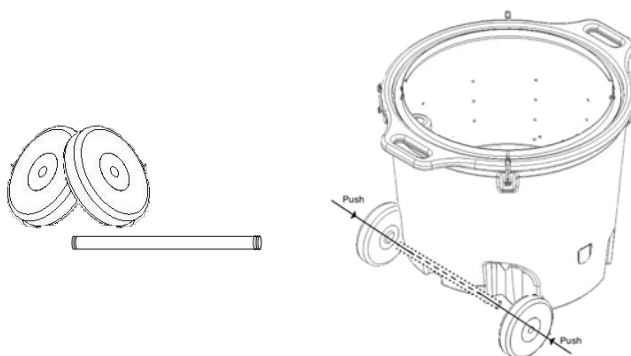



## STEP 5: INSTALL THE IN-SERVICE CHAMBER

- 1** Add 50mm of bulking agent to the chamber.



- 2** Slide the lid up the waste chute.  
Tip: Install bungee loops under the floor and knobs on the lid to help hold it up.

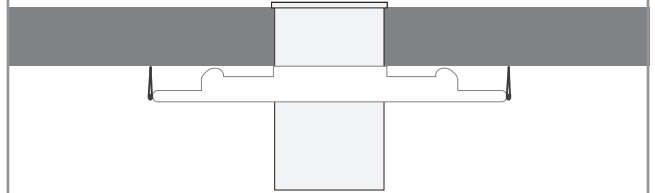

- 3** Place the chamber underneath. Lower the lid onto the chamber, lining it up with the mixers.

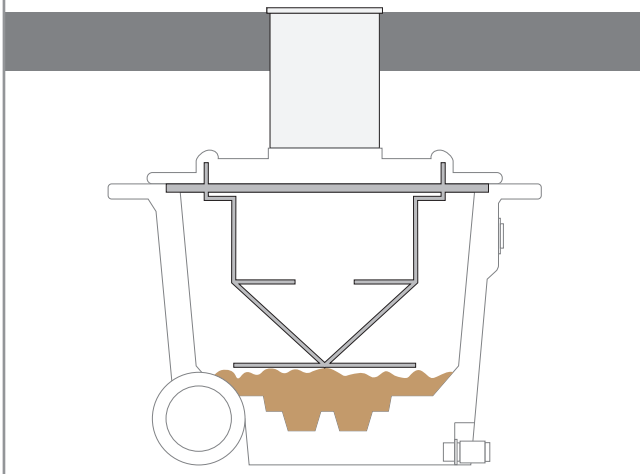

- 4** Hook the chamber bungee loops around the lid like below.

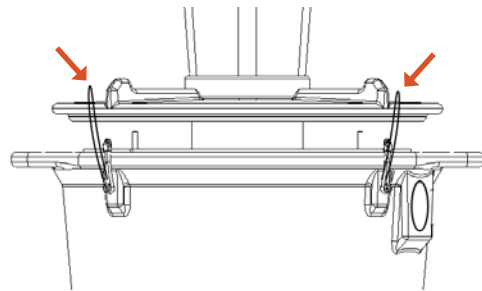

## STEP 6: CONNECT THE VENT PIPE AND FAN

The fan is IP68 rated so will not be effected by moisture.

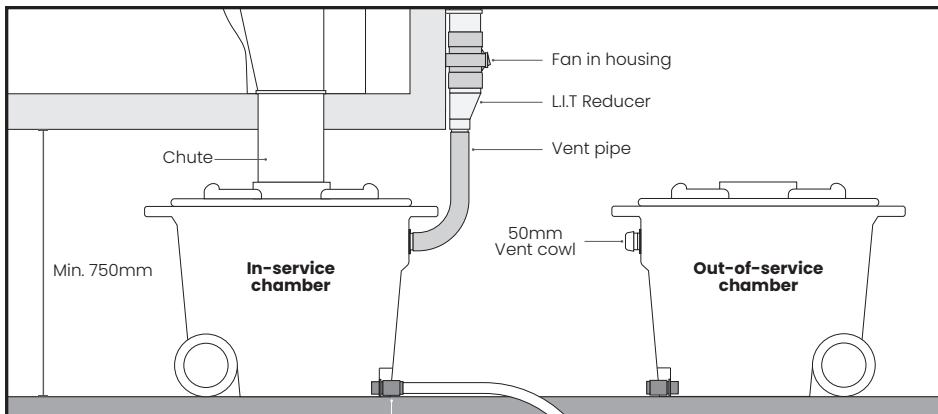

Do not glue the fan housing to the DWV fittings.

**It is recommended that the fan runs 24 hours a day to continuously circulate air through the compost heap.**

Air is drawn down the toilet pedestal, through the compost chamber and out the vent pipe.

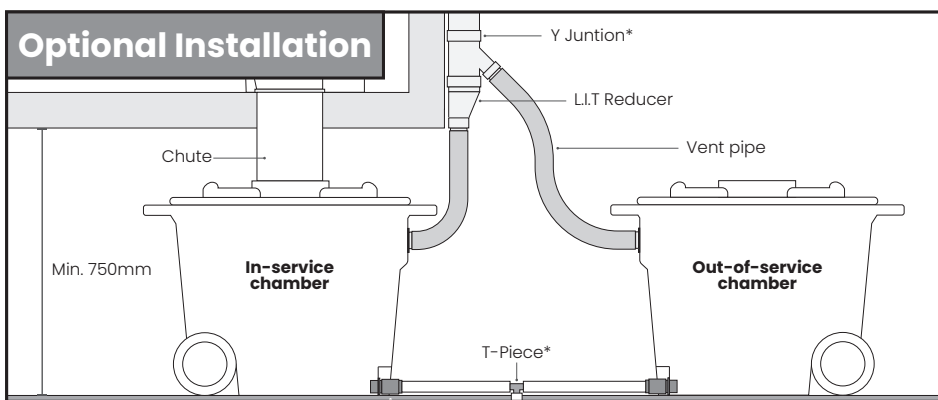

## OPTIONAL EXTRAS

These optional kits are available to purchase from Ecoflo Wastewater Management.

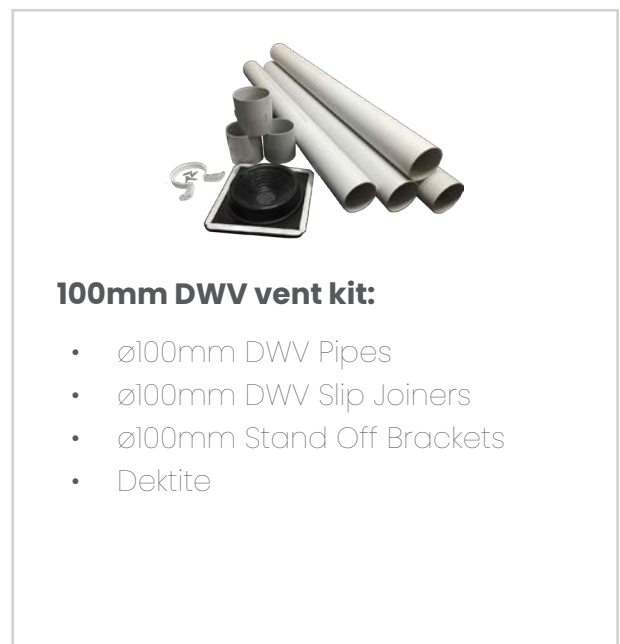
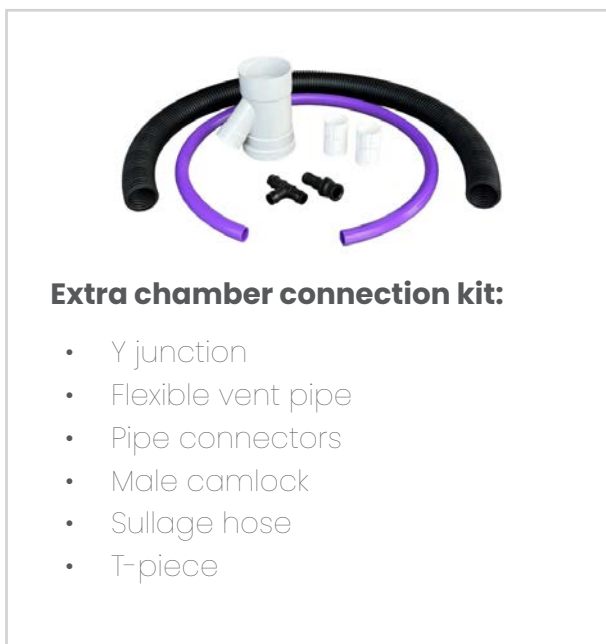

## STEP 7: CONNECT THE FLEXIBLE VENT PIPE AND LIQUID DRAIN HOSE

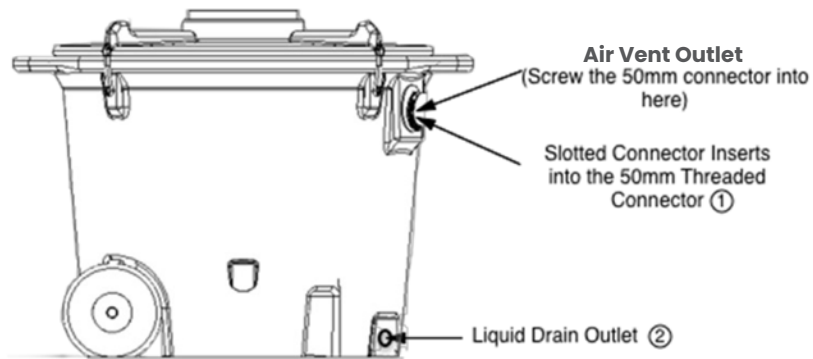

1



Dip the ends of the vent pipe into hot water for easier insertion of the pipe connectors.

2



Dip the end of the hose into hot water for easier insertion of the barbed fitting. Ensure the hose is pushed entirely onto the barbed camlock.

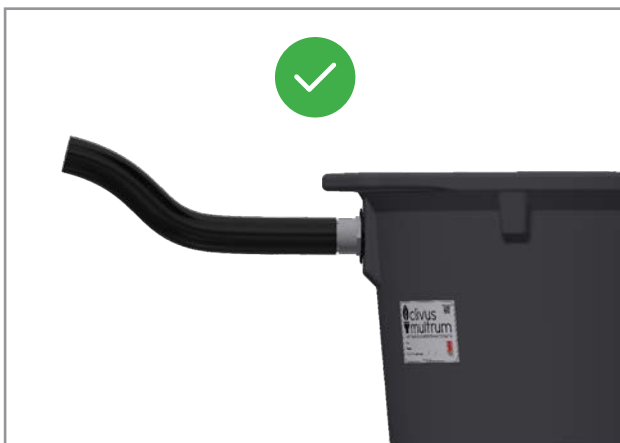

# POWERING YOUR FAN

A 240/12 volt regulated transformer is included to run the fan from mains power. The positive wire on the transformer is marked with a white line. The fan has anti-polarity protection and would not run if connected incorrectly. It is recommended to keep a spare fan, particularly after a year of use. If you have a solar panel, refer to the instructions provided with it.

## Connect the fans to the transformer as follows:

- 1** If the housing has external IP plugs, simply connect the two plugs and screw the IP cap over the port to secure.
- If the transformer cables have wire stripped ends, proceed to **step 2**.

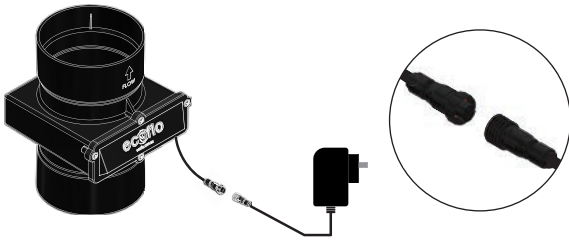

- 2** Unscrew the fan housing cover.

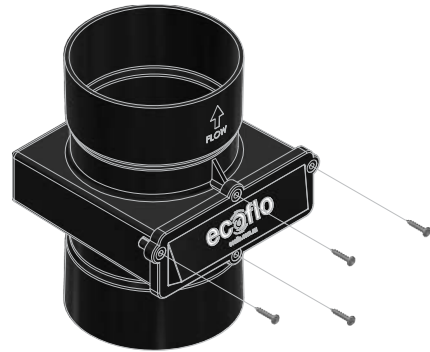

- 3** Attach the transformer cables to the terminal block as shown below.

**Black to black (negative)**  
**Red to black with white stripe (positive)**

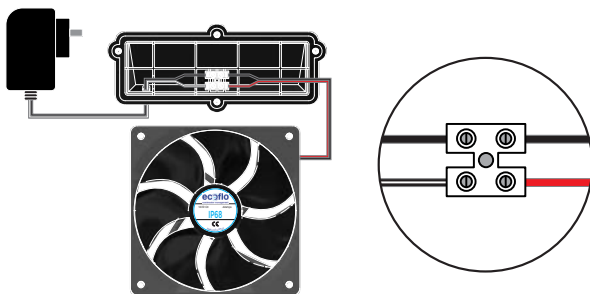

The fan has anti-polarity protection and will not run if connected incorrectly.

- 4** Insert the fan with sticker facing up and fan mesh into the housing, with the fan mesh on top.

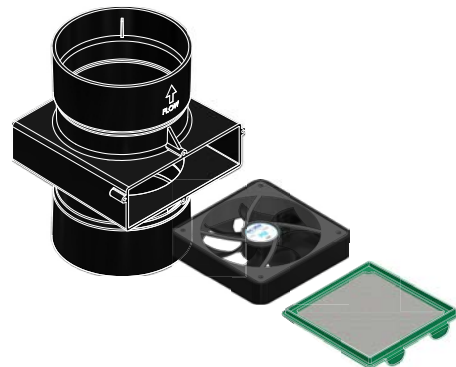

- 5** Test the fan. Airflow should be directed upwards, towards the top of the fan housing (see arrow). Screw fan cover back onto housing.

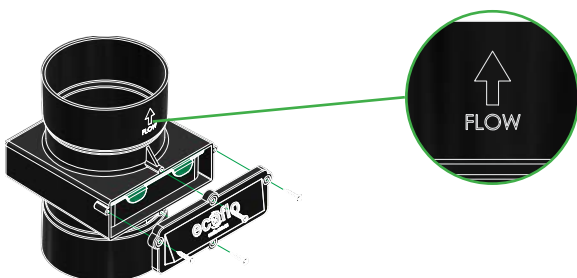

## Replacing the fan:

For fans connected with IP plugs, disconnect the fan as shown below and replace. For those with stripped cables, refer to step 2-5.

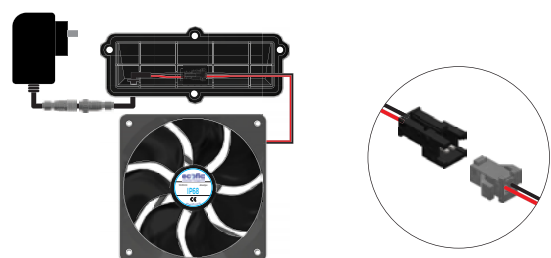

# LEACHATE DRAIN

A leachate drain kit (not including gravel) is available to purchase separately from Ecoflo Wastewater Management.

Alternatively, if your council allows, you may wish to construct your own leachate drain. The liquid drain hose should run into either a 50mm PVC pipe (drilled to allow liquid to escape) OR a length of socked slotted Ag pipe, buried in an absorption trench as shown in the diagram below.

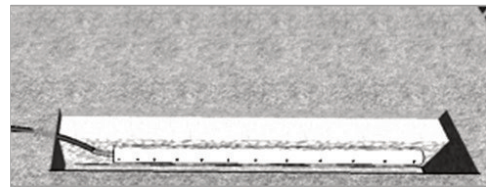
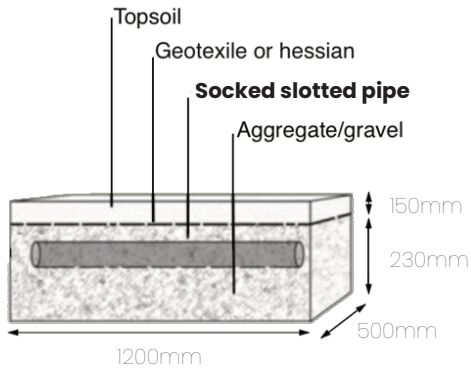

## AGI DRAIN

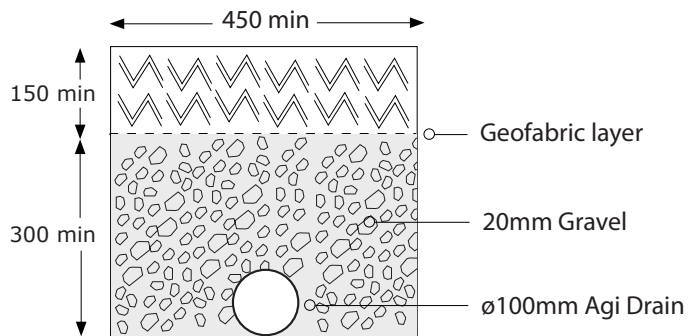

## TRENCH ARCH DRAIN

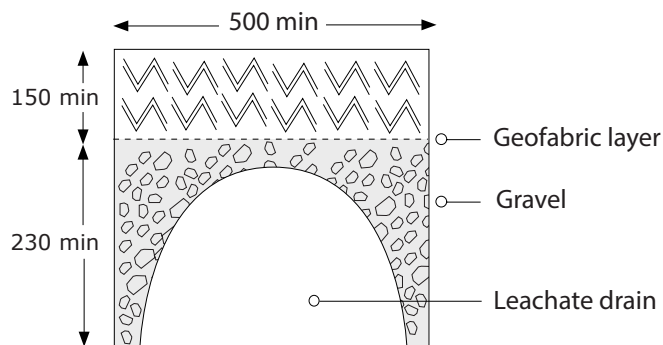

# COMPOST ACCELERATORS

Whilst Clivus Multrum users report successful composting without the use of any additives, we strongly recommend the use of the following items in order to optimize composting, particularly when the toilet is in permanent use by more than two people.

## BULKING AGENT

When starting or restarting with an empty chamber, add a 50mm starter bed of bulking agent.

This should be added on a regular basis, preferably a handful after each solid use. Alternatively, if this is not possible, add the equivalent of this on a daily or weekly basis. The bulking agent can be added through the pedestal.

For best results use pine wood shavings or hemp bedding (available to purchase from Ecoflo, or find at your local hardware or pet store).

### We do NOT recommend the use of:

- Sawdust - as the small particles can create an anaerobic condition within the chamber and small particles can disrupt ventilation.
- Cypress, cedar or eucalyptus wood shavings - due to their antimicrobial properties.
- Sugar cane mulch - as it makes using the mixer difficult. Any excess sugar leaching into the compost can attract bugs.



## LIQUID ENZYMES

Enzymes are a natural detergent, not harmful to the culture of microorganisms in the compost pile. The enzymes act as catalysts, breaking down grime and mineral deposits into their basic elements, and helping to accelerate the composting process. Any stain on the pedestal can be removed with the solution. Refer to instructions on the bottle.



## MICROBES

Microorganisms aka microbes are the ones doing the composting in your toilet. Each microbe packet is full of aerobic microbes, actinomycetes bacteria and fungi which combine with the natural bacteria in the waste to convert it into nutritious fertile compost. Refer to instructions on packet.



# STARTING WITH AN EMPTY CHAMBER

- 1** Before connecting your chamber to the waste chute, add an even 50mm layer of bulking agent and dampen slightly with water. Complete the installation of the chamber (refer to Step 5, Install the In-Service Chamber). You can start using your chamber now.

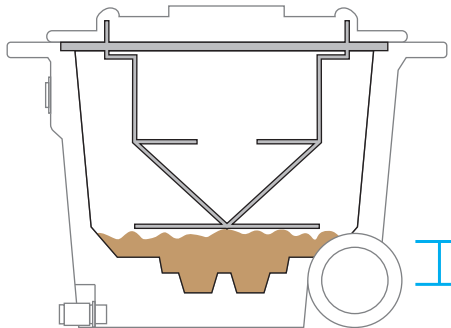

50mm of  
bulking agent

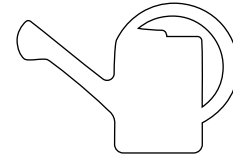

Slightly dampen the  
bulking agent with water.

- 2** After 7 days of use, mix half a packet of microbes with warm water in a bowl. Add this to the chamber through the pedestal. Reseal the packet and store it at room temperature, out of direct sunlight.

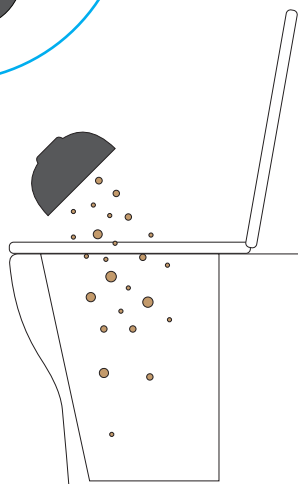

- 3** Around 14 days later, add the rest of the packet of microbes mixed with warm water to the chamber through the pedestal. Your system is now fully activated with live bacteria.

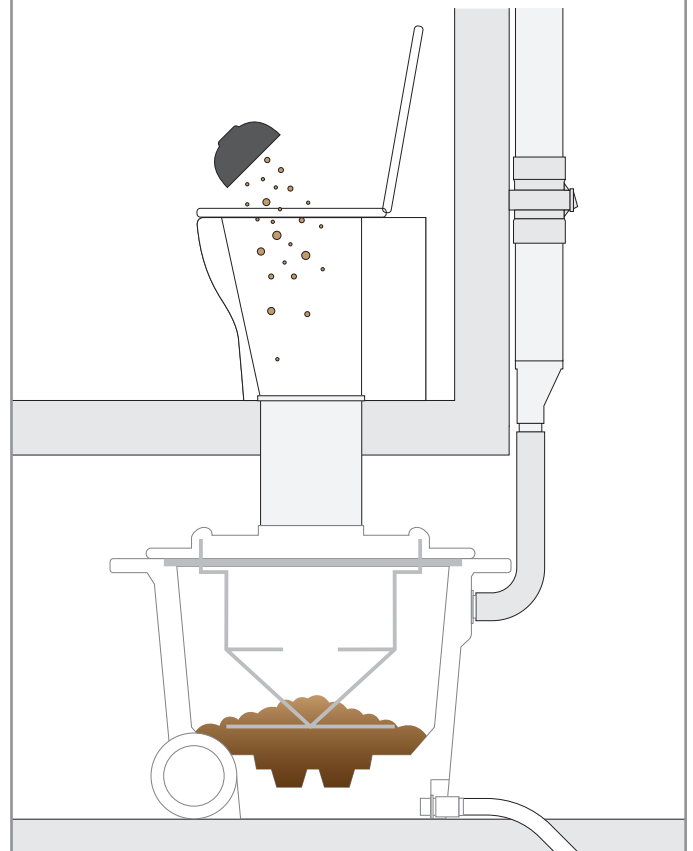

- 4** Repeat steps 1-3 each time you restart with an empty chamber.

# OPERATION

## AFTER EVERY LIQUID DEPOSIT

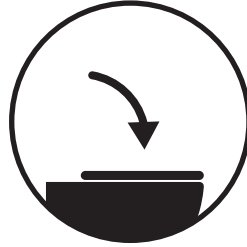

Close the lid

## AFTER EVERY SOLID DEPOSIT



Throw in a generous cup of bulking agent



Spray 10 squirts of enzymes around the bowl

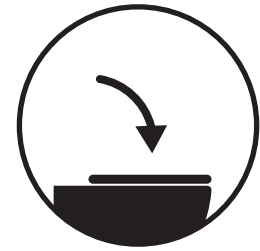

Close the lid

## DO NOT DISPOSE INTO THE COMPOST CHAMBER



Food waste



Chemical products or cleaning agents (including disinfectants)



Sanitary products and nappies



# MAINTENANCE

## DAILY OR WEEKLY

- Clean restroom and toilet fixtures using only biodegradable cleaners (enzymes)
- Add 1 cup of bulking agent to toilet after every solid use
- We recommend mixing the compost (via the mixer and crank handle) about once a week

## MONTHLY

- Inspect the 'In-service' chamber, depends on usage, prepare another 'In-service' chamber for use once the chamber becomes full (refer to Rotation of Chambers)
- Check vent pipe and remove any foreign matter
- Check the fan is operating
- Check that system is draining correctly

## 6 MONTHS

- Remove and clean the fan. We recommend to spray the fan with WD40 to help loosen any dust in the ball bearings and extend its lifespan.



It is important to observe safety procedures when dealing with fresh human waste.

Please ensure you wear protective clothing (gloves and old clothes).

Do not attempt to move the chambers on your own.



# ROTATING THE CHAMBERS

The chambers will need to be changed on a regular basis. A sufficient number of chambers must be purchased to allow the 'out-of-service' chamber a minimum of 6 months to compost (depending on the climate) from the time they are disconnected from the waste chute.

## SAFETY WEAR



When handling compost it is important to protect yourself from exposure to any potential pathogens. Wear safety materials such as gloves, long sleeves, goggles and a dust mask.

- 1** Pour a small bucket of bulking agent down the pedestal to cover up the waste pile before removing the full chamber.

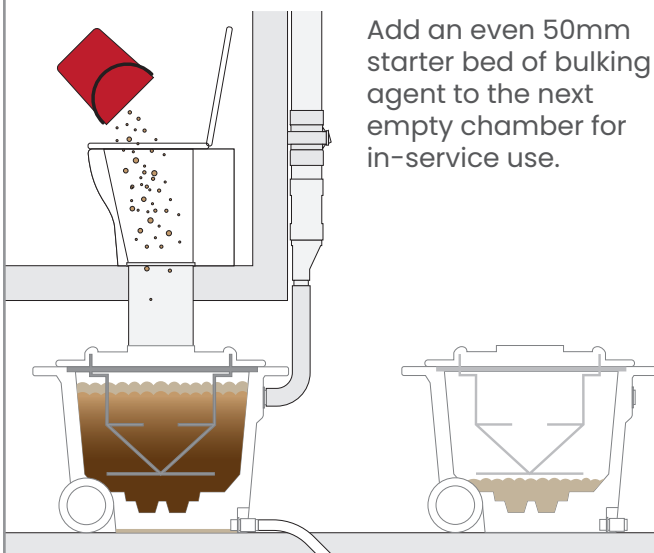

- 2** Disconnect the vent and drain system from the chamber, and immediately plug the liquid drain outlet with the dust plug. Lift the in-service lid up the chute and leave it there.

Remove the chamber from under the floor. Place the lid of the empty chamber onto the full chamber.

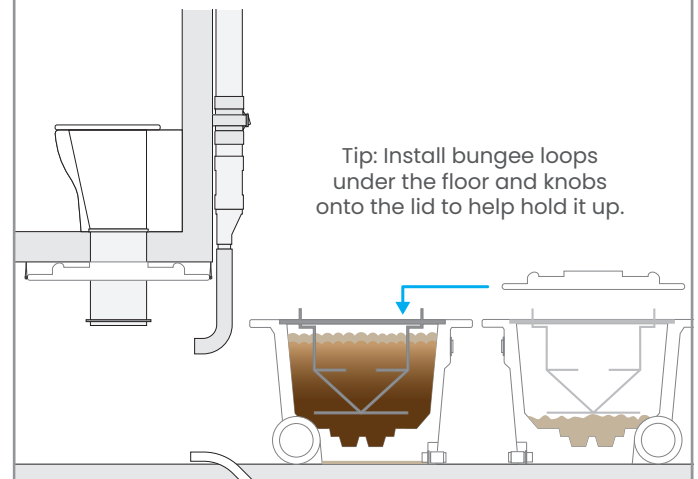

- 3** Place the new in-service chamber under the chute. Lower and lock the lid. Connect the vent and drain system.

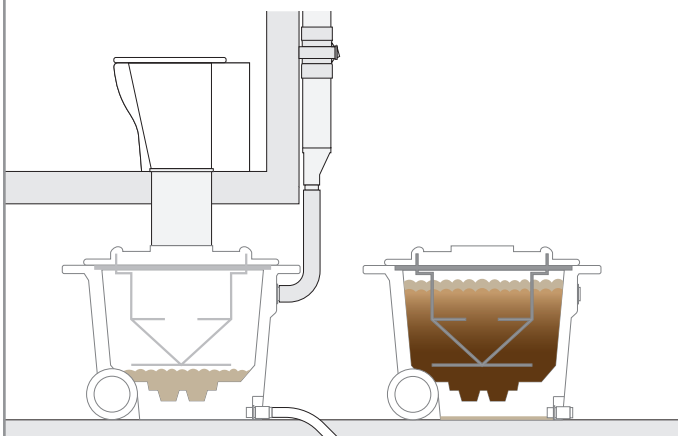

- 4** Add the 50mm pipe and vent to the out-of-service chamber. We recommend placing this chamber in a warm, sunny position until it has finished composting.

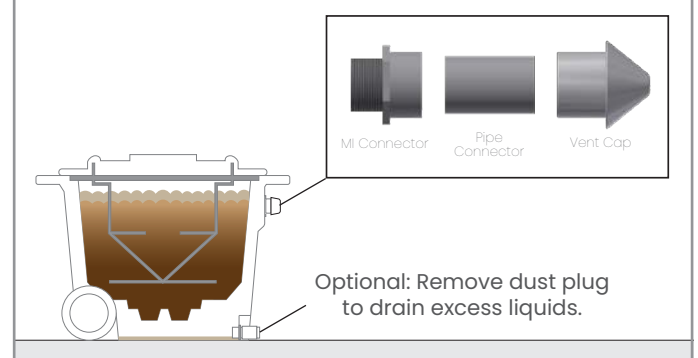

## HOW CAN I TELL IF MY COMPOST IS READY?

The size of the pile should have reduced in size by approximately 20%. Finished compost should appear crumbly and moist (similar to fresh potting mix), not sodden or dry. It should not have any offensive odour, just an earthy one. Also, the pile should not be producing high heat any longer.

## WHAT CAN I DO WITH COMPOSTED MATERIAL?

The compost must be disposed of as per the local health department regulations. This normally means burying the compost 100mm below the surface of the ground so that it does not get moved around by people or animals walking over it. You could bury compost around fruit and nut trees, lawns, flower beds or shrubs.

Avoid contact with edibles such as vegetables, herbs, and plants for harvesting seeds (eg. sunflower, sesame). Although thermophilic composting reaches temperatures high enough to kill pathogens, we want to avoid any chances of contamination.

## EXPLANATION OF THE COMPOSTING PROCESS

Our composting toilet uses a natural aerobic process called Thermophilic composting. Basically, aerobic microbes, actinomycetes bacteria and fungi generate heat and break down waste into odourless compost that's safe to handle.

To explain it in detail, it begins with the piling and layering of waste and carbon-rich materials like wood shavings. Initially, mesophilic microorganisms break down easily decomposable materials, releasing energy in the form of heat. As the temperature surpasses 45°C (113°F), thermophilic microorganisms, including heat-tolerant bacteria and fungi, become dominant. These microorganisms rapidly decompose complex organic compounds, generating even more heat.

The sustained high temperatures in the thermophilic phase accelerates the breakdown of organic matter, kills pathogens, and promotes nutrient release. The compost pile naturally cools down after the thermophilic phase, allowing mesophilic microorganisms to continue decomposition at a slower pace.

For optimal performance, microbes require composting conditions that include:

- a minimum temperature of 12°C
- moisture content of about 70%
- 30:1 carbon-nitrogen ratio
- oxygen/airflow

Microbes require a balanced diet of carbon and nitrogen to thrive and carry out their metabolic processes effectively. Simply put, carbon provides a source of energy, and nitrogen in the urine and faeces is for growth and metabolic activity.

# TROUBLESHOOTING

Clivus Multrum toilets have proven themselves to be one of the easiest systems to manage. However, being a natural process, reliant on a number of factors beyond our control, it can occasionally need some help to maintain an appropriate balance.

## **THE 'IN-SERVICE' CHAMBER IS FILLING TOO QUICKLY:**

This may be caused by a number of factors:

### **THE TEMPERATURE IS TOO LOW**

for effective composting.

### **INSUFFICIENT AIR FLOW**

This can be caused by a broken fan or the chamber being too full. Check the fan is operating and the level of the pile is not too high. This problem could also be caused by a blocked insect screen in the vent cowl.

### **THE PILE BEING TOO WET**

This could be the result of the outlet of the liquid chamber being blocked and causing the upper chamber to flood. Check the drain hose is not blocked and flush with a hose if necessary. You may need to change chambers if the blockage is in the chamber and thoroughly flush out the contents of the liquid chamber.

### **ANTIBIOTICS AND DISINFECTANTS WILL SLOW DOWN OR STOP THE PROCESS**

Restart the composting by reintroducing microorganisms. In many of these situations Nature Flush Enzymes will help solve inefficient composting by breaking down the solids and thereby speeding up decomposition.

## **THE 'OUT-OF-SERVICE' CHAMBER IS COMPOSTING TOO SLOWLY:**

This may happen due to one or more of the problems described above. At this point the most effective course of action is to aerate the pile by turning it over with the Compost Mixer. You could also add 500ml of Nature Flush Enzymes from a domestic spray bottle as you turn the material and add a quantity of Nature Quick Microbes.

You should consider locating the chamber where it has a greater exposure to direct sun light. However, if you find the pile is drying out too quickly put the chamber in a shadier position.

If you find none of the above measures are effective, it means the local climatic conditions are less than ideal. This can happen in cold or humid conditions and you will need to purchase an additional chamber in order to provide an extended composting period.

If you need to change your 'In-service' chamber and the 'Out-of-service' chamber is not yet composted, dispose of the waste as normal and order an extra chamber from Ecoflo.

## **THE ODOUR FROM THE 'OUT-OF-SERVICE' CHAMBER IS UNPLEASANT:**

If the 'Out-of-service' chamber is not connected to the vent pipe it may smell immediately after it has been taken 'Out-of-service'. Odours can be greatly reduced or eliminated by covering the top of the pile with straw or dry grass clippings. You may wish to do this before disconnecting the chamber.

## **THE ODOUR FROM THE 'IN-SERVICE' CHAMBER IS UNPLEASANT:**

If this is not caused by a failed fan, or blockage in the vent pipe, liquid drain hose or fitting, please see the "In-service' chamber is filling too quickly" section for how to resolve this problem.

## **THE POWER HAS FAILED RESULTING IN TOILET ROOM ODOURS:**

Cover the pedestal with cling film until the power is restored. If you are connected to mains power consider installing an Uninterrupted Power Supply (UPS), available at Ecoflo. The UPS will cut in with power from a 7Ah battery when there is a loss of mains power.

### **Helpful hints from our customers:**

- Paint the Vent Stack black to produce an upward air flow.
- Add a wind assisted turbo vent to the Vent Stack.



Find more Troubleshooting and FAQ information online at

[ecoflo.com.au/FAQ](https://ecoflo.com.au/FAQ)

or email us at

[info@ecoflo.com.au](mailto:info@ecoflo.com.au)

# PRODUCT & COMPONENT WARRANTY

Ecoflo will furnish new parts to a customer whose toilet fails within the allotted warranty period for the particular component, provided that our inspection shows such failure is due to defective material or workmanship. Any part supplied is warranted for the balance of the original warranty period. The warranty period for a part begins from the date the original product was dispatched (plus 10 working days for transportation).

## WARRANTY PERIOD:

Any electrical component including solar	1 year
Any rotomoulded component	10 years
Any porcelain/polymarble component	4/5 years
Toilet seats	1 year
Any other component	1 year

## THIS WARRANTY DOES NOT COVER:

- Damage resulting from neglect, abuse, accident or alteration; or damage caused by fire, flood, acts of god or other causality.
- Damage resulting from failure of the purchaser to follow normal installation and operating procedures outlined in the manual or in any other printed instructions supplied with the system.
- Labour and service charges incurred in the removal and replacement of any parts found defective under this warranty.

Items subject to a dispute, where photographic evidence is inconclusive, must be sent prepaid to Ecoflo. The cost will be reimbursed by Ecoflo should the claim be found valid.

**In addition to the above,** Ecoflo will only replace a fan that fails during the warranty period under the following conditions:

- The fan has only ever been connected and powered by either a 12 volt transformer plugged into mains power or a solar system supplied by Ecoflo. Connecting your fan directly to a power source other than one supplied or specified by Ecoflo may result in damage to the fan and void the warranty.
- The fan and transformer must not be modified/altered in any way.
- The faulty fan is returned to Ecoflo for inspection, if required.

Providing the above conditions have been met replacement fans are shipped the same or following day free of charge by regular post.

# MAINTENANCE SCHEDULE

Please place this maintenance schedule close to your 'In-service' Chamber and complete the table as you rotate your chambers.

**Model:** \_\_\_\_\_

**Date first put into service:** \_\_\_\_/\_\_\_\_/\_\_\_\_

The 'Out-of-service' chamber must compost for a minimum of 6 months from the date it was first rotated 'Out-of-service'.

## DATE CHAMBERS WERE LAST ROTATED:



Wear protective clothing including gloves and eyewear when servicing, rotating or emptying chambers.

# CONTACT

The place of purchase is responsible for handling warranty claims and addressing product concerns during the warranty period.

## AUSTRALIA



Ecoflo Wastewater Management

[ecoflo.com.au](http://ecoflo.com.au)

PH 1300 138 182 or (07) 3889 6144

[info@ecoflo.com.au](mailto:info@ecoflo.com.au)

Available Monday - Friday (excluding public holidays)

## NEW ZEALAND



Waterless Composting Toilets NZ

[wctnz.co.nz](http://wctnz.co.nz)

PH 0800 022 027

[sales@wctnz.co.nz](mailto:sales@wctnz.co.nz)



Proudly Designed and Assembled  
in Australia by Ecoflo Wastewater  
Management





