

NL3

OWNER'S MANUAL

AUS|NZ

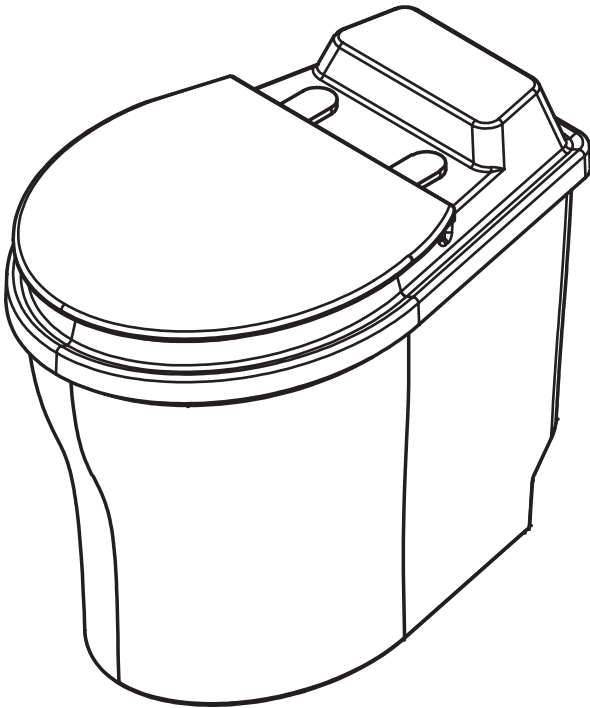

TABLE OF CONTENTS

SPECIFICATIONS	1
WHAT'S IN THE BOX?	2
ADDITIONAL ITEMS (NOT INCLUDED)	3
TOOLS REQUIRED	4
INSTALLATION OPTIONS	4
INSTALLATION INSTRUCTIONS	5
POWERING THE FAN	9
EXCESS LIQUID DRAIN	10
USING YOUR TOILET	11
HOW COMPOSTING WORKS	13
COMPOST ACCELERATORS	14
MAINTENANCE	15
TROUBLESHOOTING	15
WARRANTY	17
CONTACT US	17

SPECIFICATIONS

Capacity:	2 person full time use
Max. Load Bearing:	130kg
Material:	LDPE
Dimensions:	620L x 395W x 500H

ELECTRICAL REQUIREMENTS

Ventilation Fan:	5W 12V DC
-------------------------	-----------

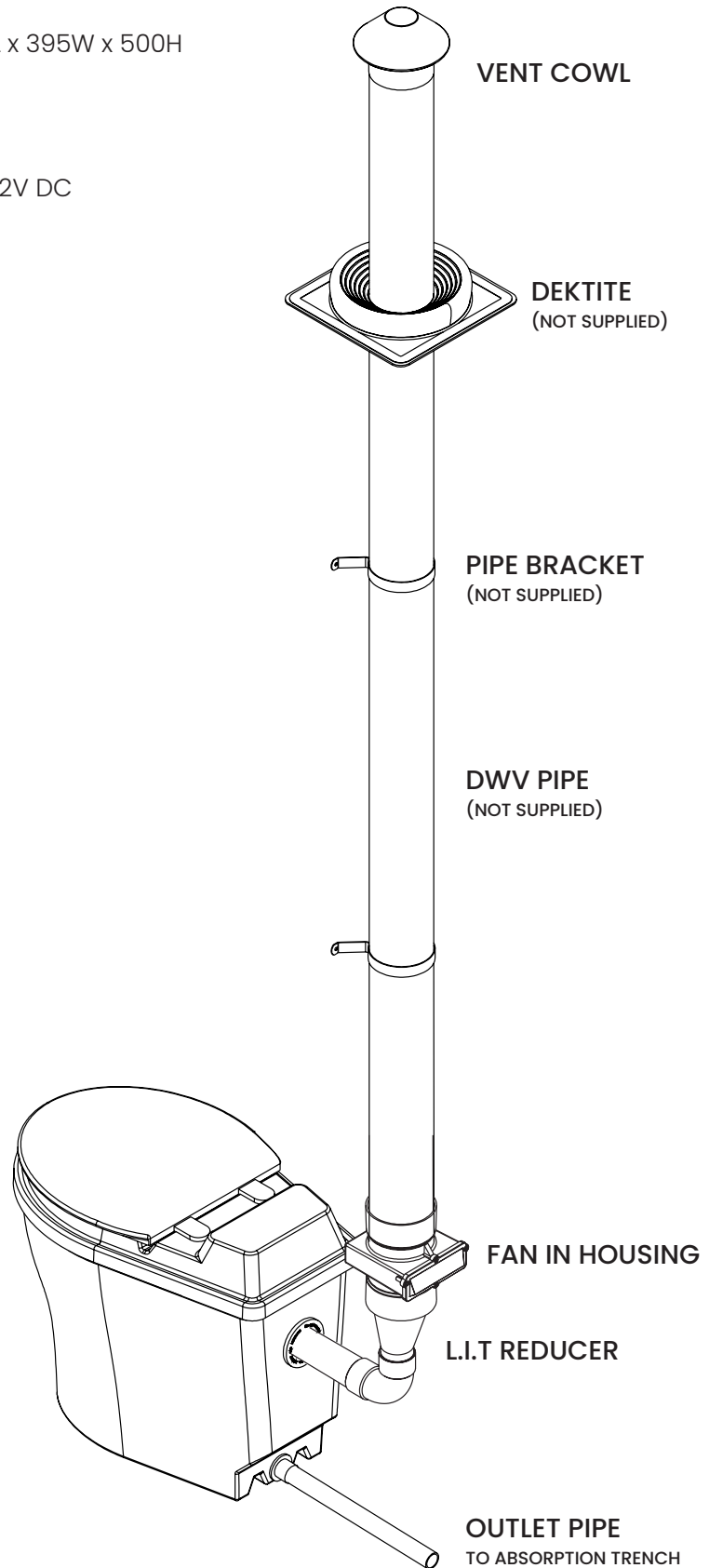

WHAT'S IN THE BOX?

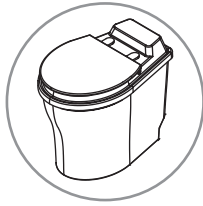

PEDESTAL WITH SEAT

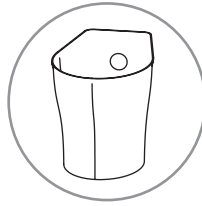

CHAMBERS, LIDS & DRIP TRAY

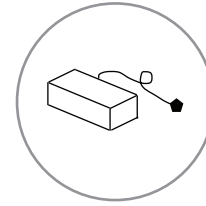

12V TRANSFORMER

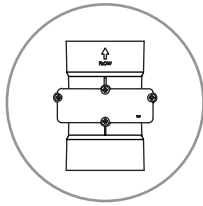

FAN IN HOUSING

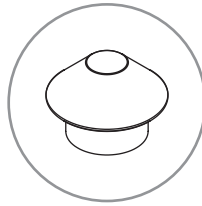

VENT COWL

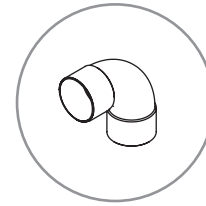

90° 50MM DWV BEND

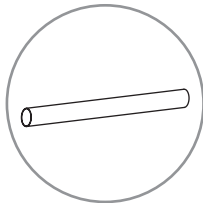

50MM DWV PIPE

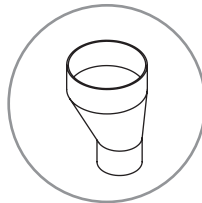

REDUCER

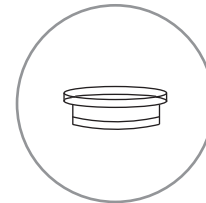

50MM WALLACE SEAL

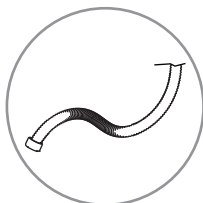

25mm SULLAGE HOSE

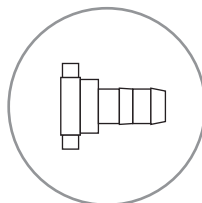

HOSE TAIL

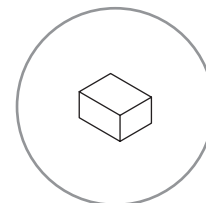

MOUNTING BLOCKS

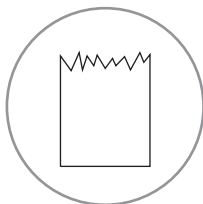

MICROBES

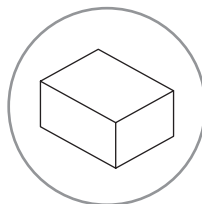

BULKING MATERIAL

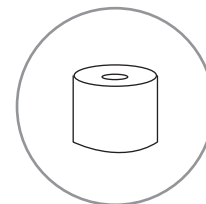

TOILET ROLL

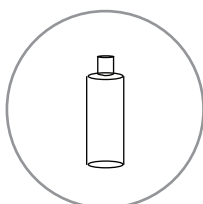

ENZYMES



SPRAY BOTTLE

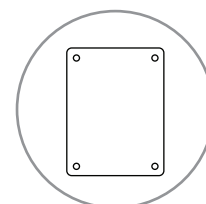

'HOW TO USE' SIGN

ADDITIONAL ITEMS (NOT INCLUDED)

Depending on the circumstances of your installation you may require the following items.

FOR THE EXCESS FLUID DRAIN

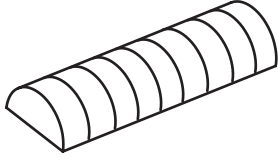

TRENCH ARCH
DRAIN



AGI DRAIN WITH
SOCK



GRAVEL

A Drain Kit can be purchased from ecoflo.com.au

FOR THE VENT PIPE

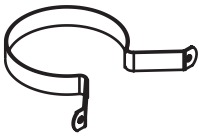

PIPE
BRACKETS



PVC GLUE



DEKTITE

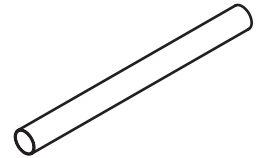

100mm DWV
PIPE

A Vent Kit can be purchased from ecoflo.com.au

TOOLS REQUIRED



Screwdriver
(Philips/
plain)



Spade



Silicone
Adhesive
Sealant

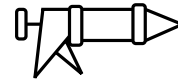

Caulking gun



PPE



Jigsaw



Tape Measure

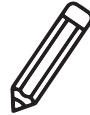

Marker



Spirit Level



Hole Saw
38mm & 65mm
(Min. sizes)

INSTALLATION OPTIONS

The toilet can be installed close to a wall with the vent pipe exiting directly through the rear wall (See OPTION 1). Alternatively, the vent pipe can be installed on the inside, exiting up through the ceiling (See OPTION 2. This must be indicated at the time of purchase).

OPTION 1

Ventilation Pipe Installed Outside

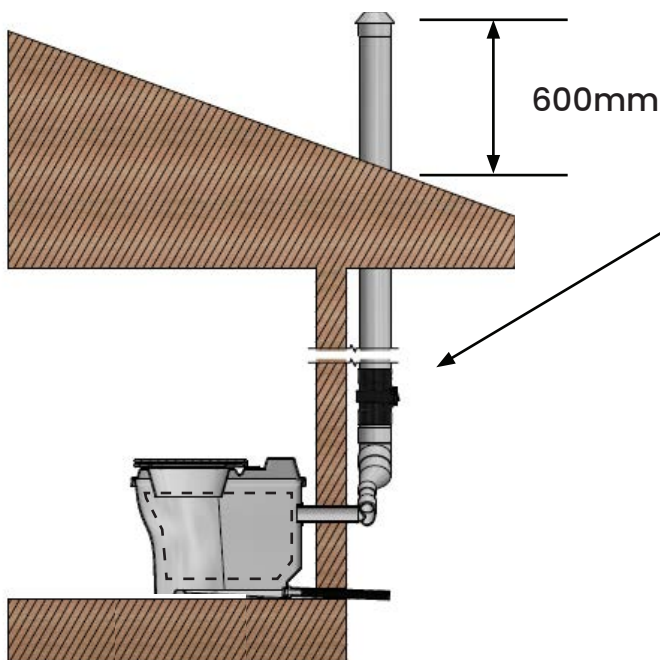

OPTION 2

Ventilation Pipe Installed Inside

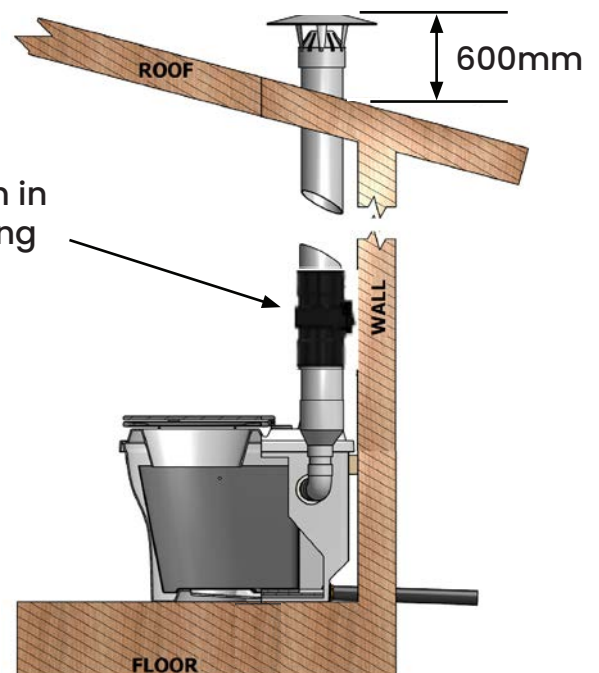

INSTALLATION INSTRUCTIONS

1

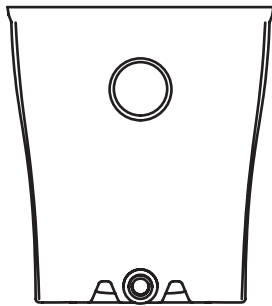

BACK VIEW

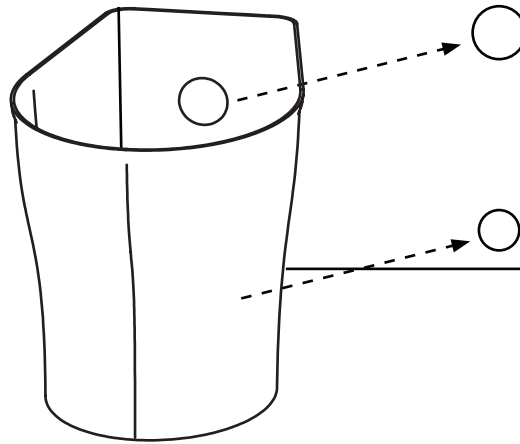

Mark holes on rear wall with pencil.

2

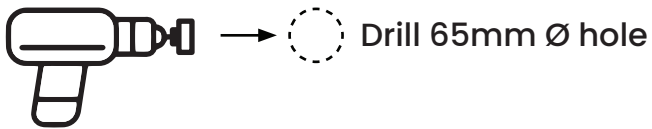

Drill 65mm Ø hole



Drill 38mm Ø hole

SIDE VIEW

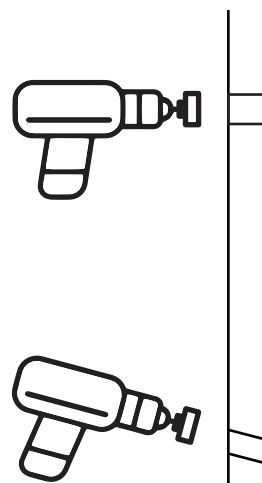

Ensure the hole for the sullage hose is sloping downwards to the outside.

3

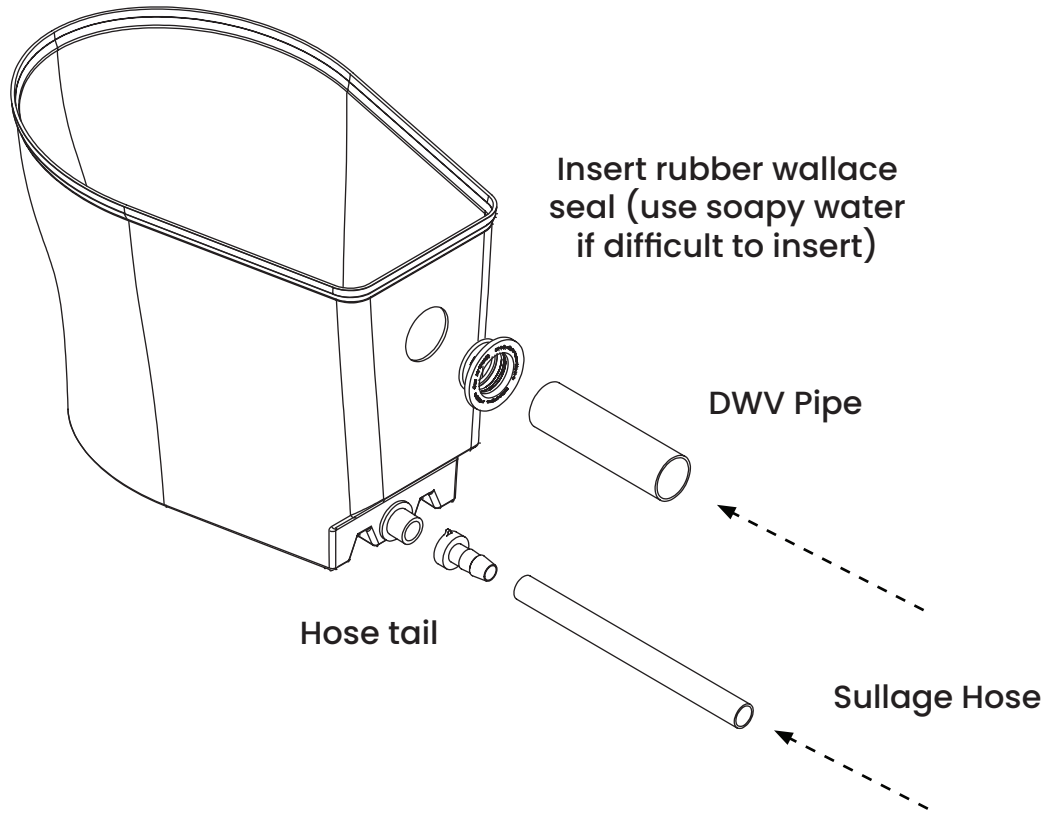

4

Feed vent pipe & sullage hose through the wall. Ensure the hose end point is lower than the pedestal outlet.

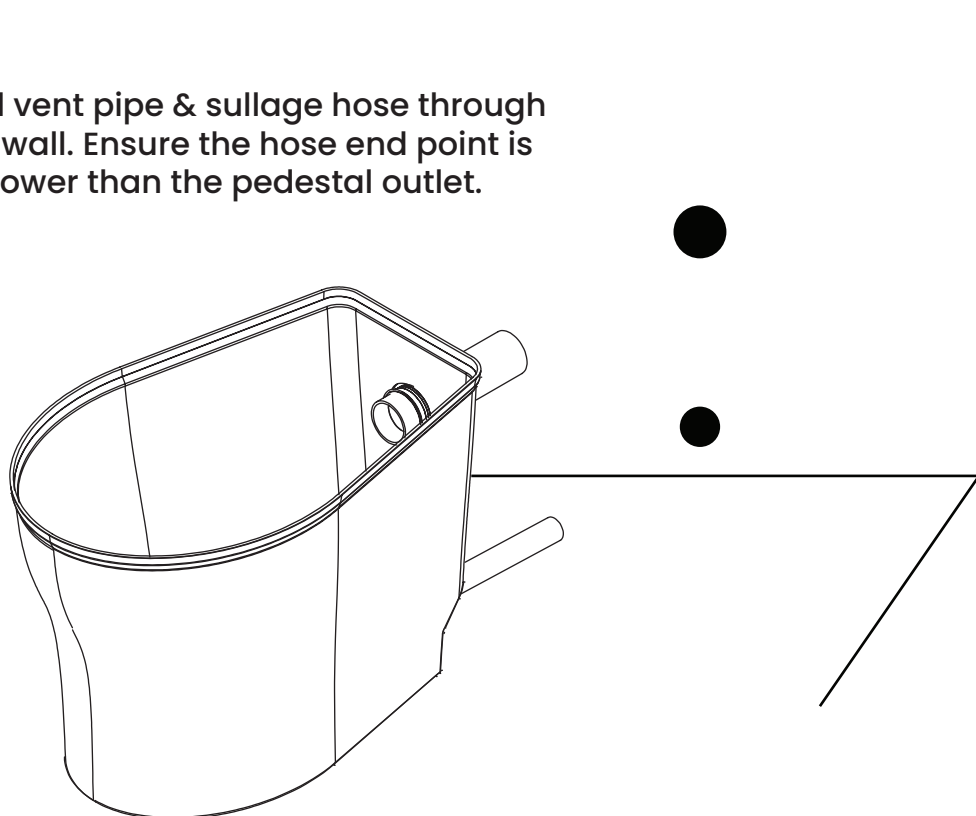

5

Secure pedestal
to wall with
mounting blocks

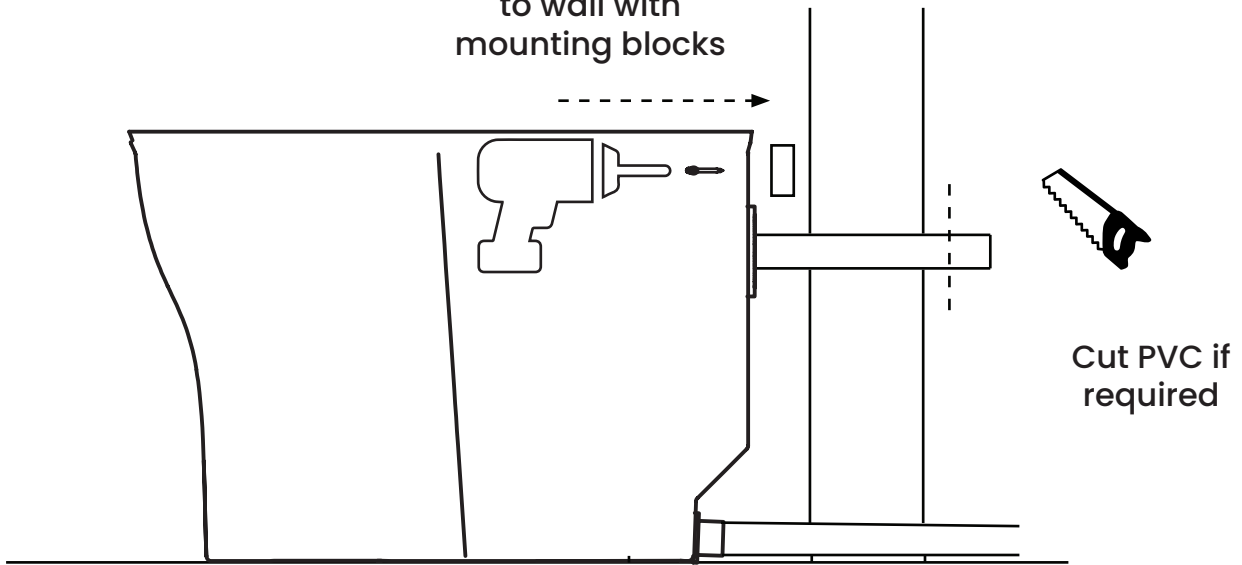

6

Connect the 90° DWV Bend and the
Reducer to the DWV Pipe.

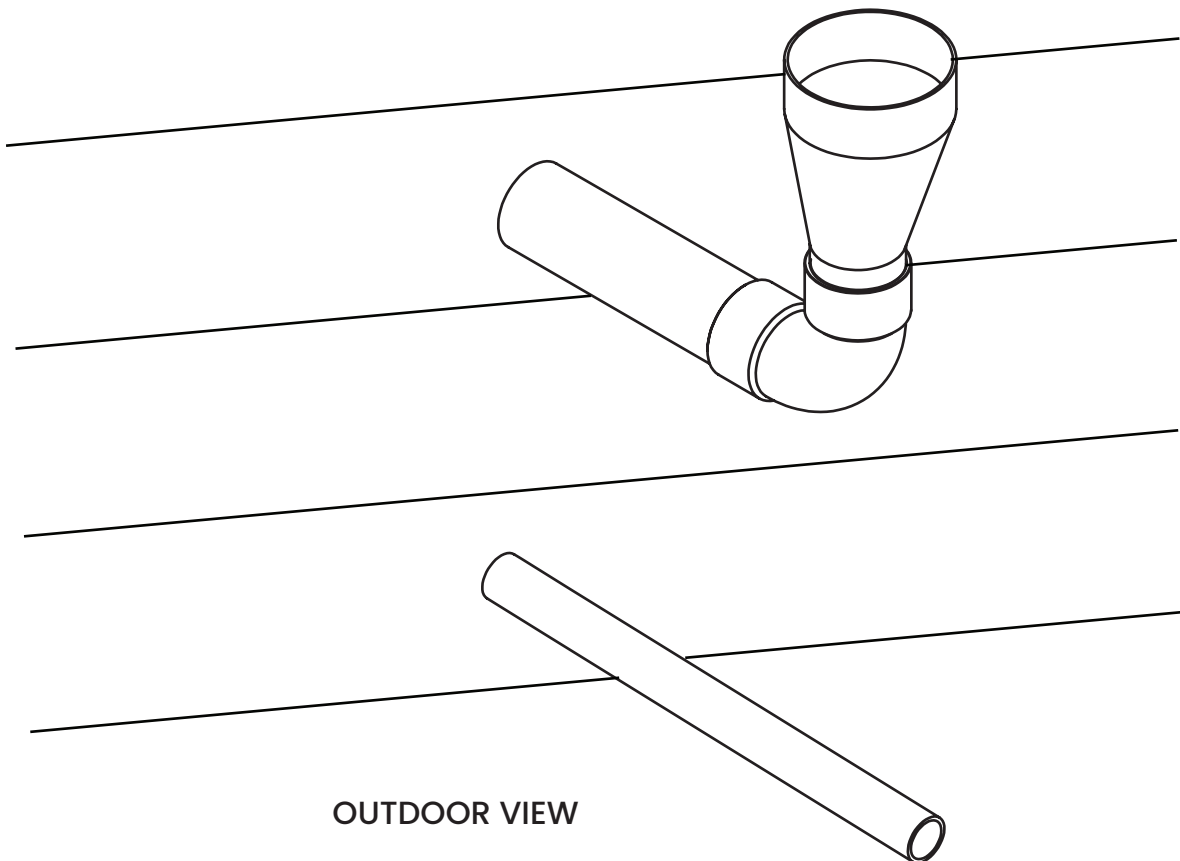

7

Connect the Fan Housing to the Reducer.

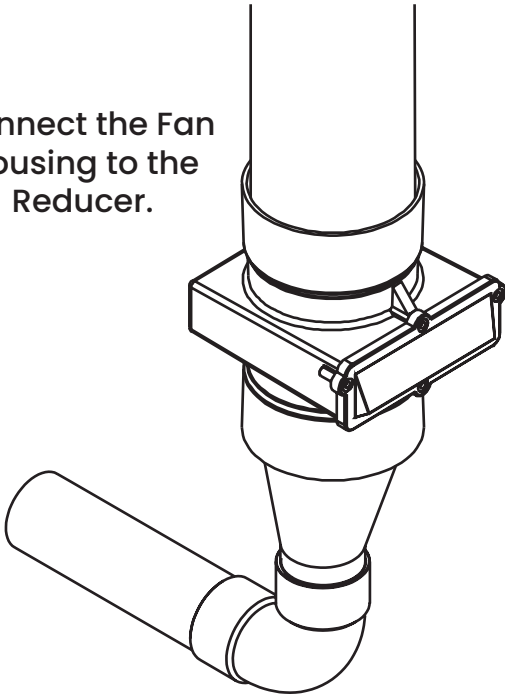

8

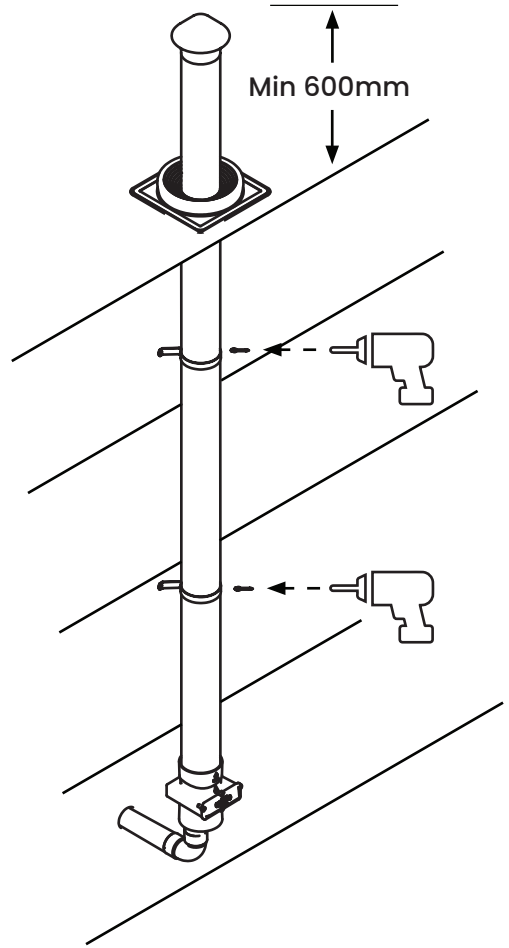

9

Installation complete!

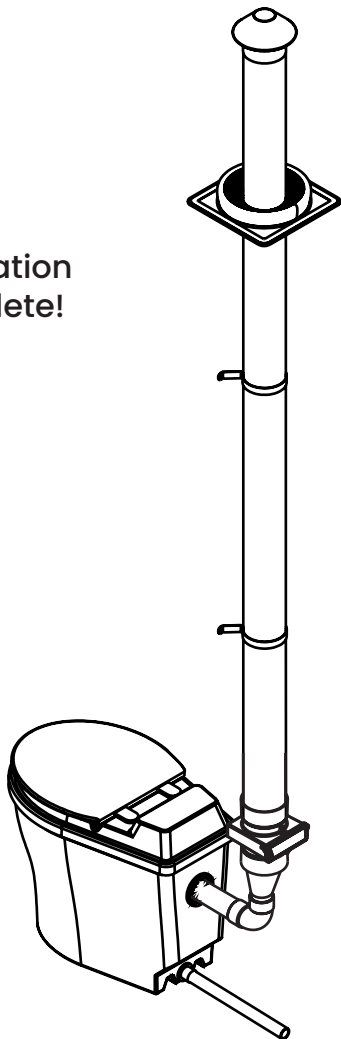

POWERING THE FAN

A 240/12 volt regulated transformer is included to run the fan from mains power. The positive wire on the transformer is marked with a white line. The fan has anti-polarity protection and would not run if connected incorrectly. **NOTE: The fan should run 24 hours a day to continuously circulate air through the compost heap.**

Connect the fans to the transformer as follows:

- 1** If the housing has external IP plugs, simply connect the two plugs and screw the IP cap over the port to secure. If the transformer cables have wire stripped ends, proceed to **step 2**.

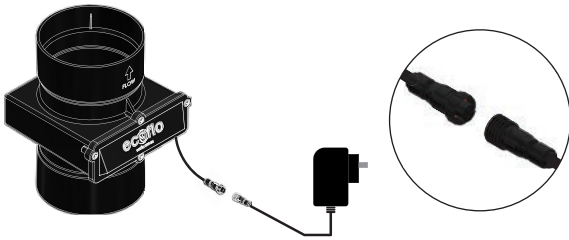

- 2** Unscrew the fan housing cover.

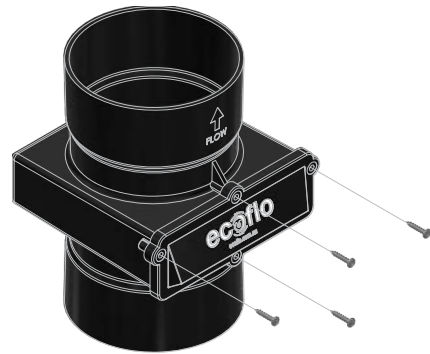

- 3** Attach the transformer cables to the terminal block as shown below.

Black to black (negative)
Red to black with white stripe (positive)

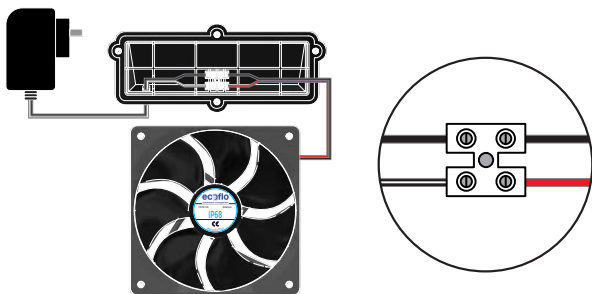

The fan has anti-polarity protection and will not run if connected incorrectly.

- 4** Insert the fan with sticker facing up and fan mesh into the housing, with the fan mesh on top.

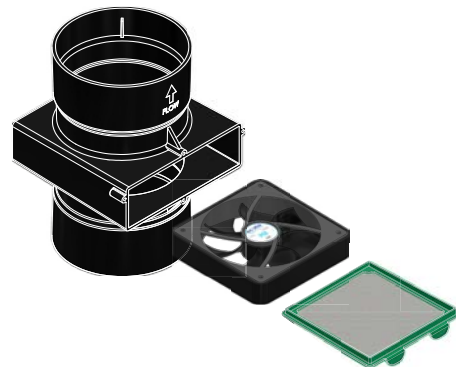

- 5** Test the fan. Airflow should be directed upwards, towards the top of the fan housing (see arrow). Screw fan cover back onto housing.

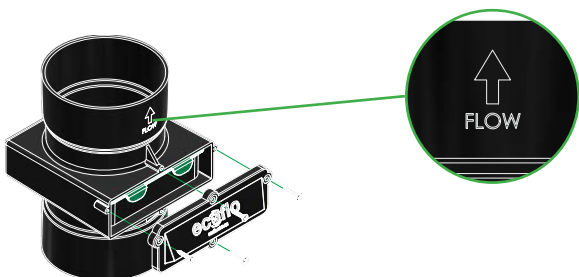

Replacing the fan:

For fans connected with IP plugs, disconnect the fan as shown below and replace. For those with stripped cables, refer to step 2-5.

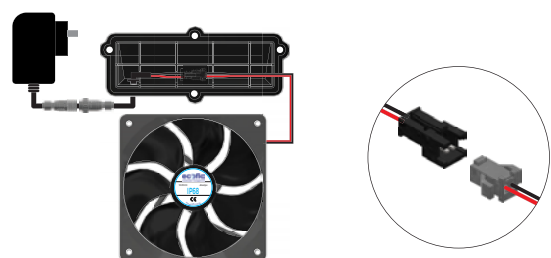

EXCESS LIQUID DRAIN

The drainage system to be chosen depends entirely on the soil condition, ground water level, and local regulations. Please ensure you choose your location with this in mind.

ABSORPTION TRENCH INSTALLATION

This is the normal method for disposal of excess liquid, but refer to council for permit for any specific requirements. These instructions apply to installation of the drain kit items available from Ecoflo.

1. Dig a trench in a position located in front of the liquid end product drain.
2. The trench is to be located in soil of good permeability and in a position where ground water will not flood the unit.
3. If there is some doubt as to the permeability of soil, extra trenching length may be required especially if a hand basin or other fittings will also drain into the same trench.
4. The liquid leaving the compost unit when in use is not expected to exceed 1 litre per day per resident.
5. In some locations it may be desirable or necessary to connect the excess liquid drain to a grey water system or an alternative disposal method complying with AS/NZS 1547:2012.
6. Trench dimensions and construction are to be in accordance with AS/NZS 1547:2012, as shown in Figure 5.

It is important to ensure that the trench is level along its length. Ensure the liquid drain pipe slopes away from the toilet and towards the trench. The trench should be protected from surface water, flooding, and vehicle traffic.

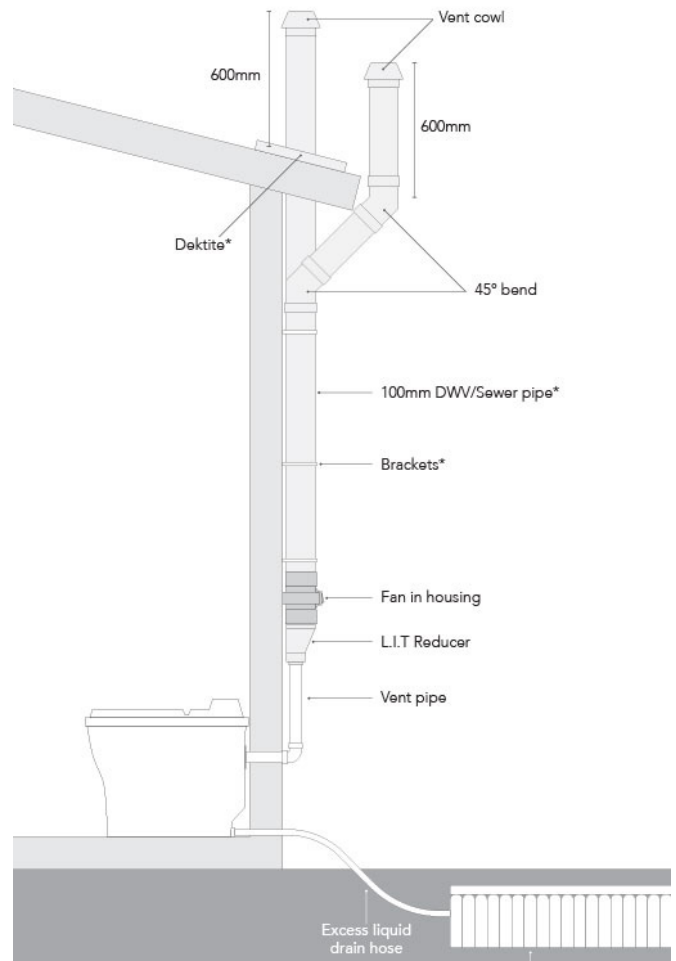
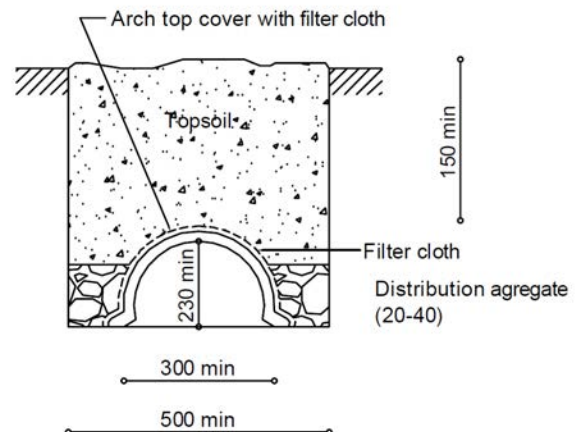

Figure 5: Durable Self Supporting Arch Trench (all dimensions in mm)



USING YOUR TOILET

STARTING WITH AN EMPTY CHAMBER

1. Once the pedestal has been installed, place one compost chamber inside the pedestal.
2. Remove the chamber lid and put back the pedestal lid. Do not misplace the chamber lid and make sure it is kept somewhere safe.
3. Connect the power outlet for the ventilation fan to power source.
4. Add an even 50mm starter bed of bulking agent to the chamber. Dampen slightly with water.
5. Sprinkle a ¼ cup of microbes mixed with warm water on top of the starter bed.
6. Your toilet is ready to be used!

OPERATION

AFTER EVERY LIQUID DEPOSIT

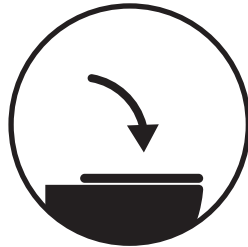

Close the lid

AFTER EVERY SOLID DEPOSIT



Throw in a generous cup of bulking agent



Spray a bit of enzyme solution around the bowl

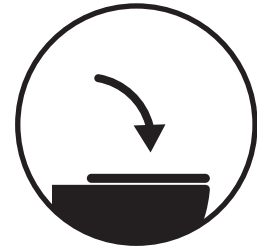

Close the lid

DO NOT DISPOSE INTO THE COMPOST CHAMBER



Food waste



Chemical products or cleaning agents (including disinfectants)



Sanitary products and nappies

ROTATING THE CHAMBER

The active compost chamber should be replaced with an empty one when it is approximately 75% full or when the pile is approximately 200mm from top of the toilet seat.

1. Remove the pedestal seat and place the chamber lid on.
2. Place the chamber onto the drip tray and lock it on with the bungee loops, like the image below.



3. Place the full chamber outside to finish composting. We recommend placing it in a warm sunny position (where direct access is restricted). You can either remove the drip tray or leave it on.
4. Place the next empty chamber into the pedestal. Keep its lid in a safe place.
5. Add an even 50mm starter bed of bulking agent to the chamber. Dampen slightly with water.
6. Sprinkle a ¼ cup of microbes mixed with warm water on top of the starter bed.
7. Put back the pedestal seat.
8. Your toilet is ready to be used again.

WARNING

Never put cigarettes or other burning material, or any sanitary products into your toilet.

HOW DO I DISPOSE OF COMPOSTED MATERIAL?

All composted product should be handled and treated with caution as there is a risk of exposure to pathogens particularly if the product is not properly composted. Recommended protective clothing includes gloves, appropriate footwear, a face mask and eye protection.

You should dispose of the composted waste in accordance with any and all local authority regulations. For an on-site burial of composted end product, it should be undertaken in a location where direct access by humans and animals is restricted. It should be buried with a minimum cover of 100mm within soil that is not intended for the cultivation of root vegetables or nearby a water catchment area.

HOW COMPOSTING WORKS

When do I empty the secondary chamber?

As a general rule, you should leave the material in the compost chamber as long as possible. This toilet has been designed for 2 people full time where the average monthly temperature is greater than 18°C in any given month. The higher the temperature (within the optimum range), the faster the compost process. As a reference, 50 days is required to reach 50% (half life) decomposition with a compost temperature ranging between 22–24°C. If there is more than 2 people using the toilet or you are in a colder area then additional compost chambers may be required. Additional compost chambers can be purchased from Ecoflo WM.

How can I tell if my compost is ready?

The size of the pile should have reduced in size by approximately 20%. Finished compost should appear crumbly and moist (similar to fresh potting mix), not sodden or dry. It should not have any offensive odour, just an earthy one. Also, the pile should not be producing high heat any longer.

Explanation of the Composting Process

Our composting toilet uses a natural aerobic process called Thermophilic composting. Basically, aerobic microbes, actinomycetes bacteria and fungi generate heat and break down waste into odourless compost that's safe to handle.

To explain it in detail, it begins with the piling and layering of waste and carbon-rich materials like wood shavings. Initially, mesophilic microorganisms break down easily decomposable materials, releasing energy in the form of heat. As the temperature surpasses 45°C (113°F), thermophilic microorganisms, including heat-tolerant bacteria and fungi, become dominant. These microorganisms rapidly decompose complex organic compounds, generating even more heat.

The sustained high temperatures in the thermophilic phase accelerates the breakdown of organic matter, kills pathogens, and promotes nutrient release. The compost pile naturally cools down after the thermophilic phase, allowing mesophilic microorganisms to continue decomposition at a slower pace.

For optimal performance, microbes require composting conditions that include:

- a minimum temperature of 12°C
- moisture content of about 70%
- 30:1 carbon-nitrogen ratio
- oxygen/airflow

Microbes require a balanced diet of carbon and nitrogen to thrive and carry out their metabolic processes effectively. Simply put, carbon provides a source of energy, and nitrogen in the urine and faeces is for growth and metabolic activity.

COMPOST ACCELERATORS

Whilst users report successful composting without the use of any additives, we strongly recommend the use of the following items in order to optimize composting, particularly when the toilet is in permanent use by more than two people.

Bulking Agent

When starting or restarting with an empty chamber, add a 50mm starter bed of bulking agent.

This should be added on a regular basis, preferably a handful after each solid use. Alternatively, if this is not possible, add the equivalent of this on a daily or weekly basis. The bulking agent can be added through the pedestal.

For best results use pine wood shavings or hemp bedding (available to purchase from Ecoflo, or find at your local hardware or pet store).



We do NOT recommend the use of:

- Sawdust - as the small particles can create an anaerobic condition within the chamber and small particles can disrupt ventilation.
- Cypress, cedar or eucalyptus wood shavings - due to their antimicrobial properties.
- Sugar cane mulch - as it makes using the mixer difficult. Any excess sugar leaching into the compost can attract bugs.

Liquid Enzymes

Enzymes are a natural detergent, not harmful to the culture of microorganisms in the compost pile. The enzymes act as catalysts, breaking down grime and mineral deposits into their basic elements, and helping to accelerate the composting process. Any stain on the pedestal can be removed with the solution. Refer to instructions on the bottle.



Microbes

Microorganisms aka microbes are the ones doing the composting in your toilet. Each microbe packet is full of aerobic microbes, actinomycetes bacteria and fungi which combine with the natural bacteria in the waste to convert it into nutritious fertile compost. Refer to instructions on packet.



MAINTENANCE

GENERAL CARE

The toilet should be examined regularly to ensure correct operation. The key areas to be checked are listed below:

- Every 6 months, check that the ventilation fan is running well. We recommend spraying it with a degreaser such as WD40 to clean and lubricate it.
- Check there is no excess liquid in the compost chamber and pedestal.

CLEANING

Use mild detergents for your toilet. Never use scouring powder or other strong detergents that could scratch the surface, or kill off your good bacteria. We recommend green friendly or septic safe products.

TROUBLESHOOTING

If you the chamber fills up too quickly or the composting process is too slow, this can be caused by ineffective composting processes due to a number of issues as listed below:

Compost pile is too dry or wet

You will notice that the compost pile is too dry if there are hard lumps, or if toilet paper does not break down. If so, sprinkle about half a litre of water over the composting pile.

If you notice that the compost pile is soggy, check if the drainage outlet is blocked. To unclog the drain, you could use a tool, hot water and an enzyme drain cleaner. Always have on safety wear including gloves and a mask. Otherwise, add some bulking agent to help absorb the excess liquids, aid in improving the carbon/nitrogen ratio (refer to section How Composting Works), and also allow air to flow more freely through the system as it loosens the compost pile.

Insufficient air flow

Without sufficient air flow, the evaporation process will be slowed and odours may start to escape into the toilet room. This can be caused by a malfunctioning fan or the ventilation system has been blocked. Check if the fan is properly connected or replace the fan if broken. Check if the insect netting has been blocked.

Continued on next page

Is your compost pile surrounding temperature too low?

In cool climates do not insulate the toilet; turn down the fan voltage to lessen cool air being drawn into the system. If odour occurs due to the fan voltage being turned down, simply turn it up slightly to increase airflow.

When taking the compost chamber out for secondary composting, make sure it is located in a warm spot preferably in direct sunlight.

How to deal with insects attracted to compost pile?

To break the breeding cycle of insects (most commonly vinegar flies) spray the compost pile with pyrethrum based insect spray for 7 consecutive days (ensure the fan is turned off while spraying). Always place a layer of bulking agent over the top of the pile in the out of service chamber to eliminate the possibility of insects laying eggs.

WARRANTY

Pedestal

- 10 years warranty.
- Any damage caused by exceeding the maximum recommended weight listed in specifications will/may void your warranty.

Chamber Screen

- 2 years warranty.

Ventilation Fan

- 12 months limited warranty.
- Powering the fan with an unregulated power source exceeding 12V or using power supply not recommended by Ecoflo will/may void your warranty.
- Any faulty fan during the warranty period should be returned to Ecoflo WM before a replacement can be provided.

All other components come with a standard 12 month warranty.

CONTACT US

We are available from 8am to 5pm, Monday to Friday (excluding public holidays).

AUSTRALIA



Ecoflo Wastewater Management

ecoflo.com.au

PH 1300 138 182 or (07) 3889 6144

info@ecoflo.com.au

Available Monday - Friday (excluding public holidays)

NEW ZEALAND



Waterless Composting Toilets NZ

wctnz.co.nz

PH 0800 022 027

sales@wctnz.co.nz

